



A member of the
AveryWeigh-Tronix Group

GSE Tank Mounts

Integrated Tank Assembly (ITA)
Model 6600 & 6700 Series
LeverMount™



User Manual

© Avery Weigh-Tronix group of companies 2009. All rights reserved.

No part of this publication may be reproduced, stored in an electronic retrieval system, or transmitted in any form or by any means, electronic, mechanical, photocopying, recording or otherwise without the prior written consent of the copyright owner, or as permitted by law or under license. Full acknowledgment of the source must be given. Avery Weigh-Tronix is a registered trade mark of the Avery Weigh-Tronix group of companies. This publication was correct at the time of going to print however; Avery Weigh-Tronix reserves the right to alter without notice the specification, design, price or conditions of supply of any product or service at any time.

All third party brands and product names used within this document are trademarks or registered trademarks of their respective holders.

Table of Contents

<i>Tank Mount Installation</i>	1
Environmental Considerations	1
Number and Capacity of Load Cells	1
Examples:	1
Prepare the Mounting Location	2
Mechanical	2
Installation	3
Concrete Footing or Floor	3
Metal Structure	3
ITA Only	3
<i>Calibration</i>	4
<i>Maximize Operational Accuracy</i>	4
<i>Additional Consideration</i>	4
<i>ITA Dimensional Drawings</i>	6
Load Cell Specifications	9
Mounting Specifications	9
Load Cell Wiring	9
<i>6600/6700 Dimensional Drawings</i>	10
Model 6600 Single Ended Assembly	10
Model 6700 Double Ended Assembly	11
Load Cell Part Numbers	12
Model 6600.....	12
Model 6700.....	12
Load Cell Specifications	12
Load Cell Wiring	12
<i>Model 7300 LeverMount® Quick Reference</i>	13
Unpacking and Setup	13
Load Cell Part Numbers	15
Load Cell Specifications	15
Load Cell Wiring	15

TANK MOUNT INSTALLATION

Environmental Considerations

- Install the vessel in an environment where temperature fluctuations are minimized and where it will be protected from wind and drafts.
- Use load cells with temperature compensation that will allow the most satisfactory performance.
- Use a shield to protect the load cells from radiant heat sources.
- If thermal expansion/contraction of the vessel is expected, choose a mount that will allow lateral movement.
- Avoid an environment where its support structure is subject to vibration. Minimize vibrations and forces transmitted via attached piping or vessel restraints.
- Select load cells and mounts with proper corrosion and moisture protection. Fully welded and sealed, stainless steel cells provide excellent protection.
- Use a junction box with appropriate environmental protection.

Number and Capacity of Load Cells

The number of vessel supports determines the number and capacity of the load cells required. It becomes more difficult to get even weight distribution on all supports as the number of load cells increases beyond three.

Examples:

UPRIGHT CYLINDRICAL VESSELS IN COMPRESSION

Three or more symmetrically mounted load cells. Three provides the most even weight distribution between cells. Other factors may require that more supports be used with the vessel for strength or stability. The fewer number of load cells, the easier to distribute the weight evenly.

RECTANGULAR OR HORIZONTALLY MOUNTED CYLINDRICAL VESSELS IN COMPRESSION

Most practical is four cells, one at each corner of the vessel. Other factors may require that more supports be used with the vessel for strength or stability. The fewer the number of cells, the easier to distribute the weight evenly.

SUSPENDED VESSELS (TENSION or COMPRESSION)

One or more load cells may be used. Using three, symmetrically mounted, load cells or fewer has the advantage of not requiring accurate adjustment of the length of the supports to distribute the weight evenly. Other factors may require that more supports be used with the vessel for strength or stability.

- Appropriate individual cell capacity: Calculate Total empty vessel weight + the maximum that the vessel can hold when filled to overflowing *divided* by the number of supports. Chose a cell that meets or just exceeds this calculation. If the vessel is mounted out of doors, additional capacity may be required to protect from wind induced overload.
- Do not needlessly oversize the load cells; Best accuracy is achieved when maximum weighing is close to the load cells capacity.
- If it is not possible to trim the corners before or after installation then the use of load cells with matched outputs is desirable. If the vessel is not symmetrical and/or the material is not self-leveling, trimming or matching is a necessity for accuracy.
- Support the vessel entirely on load cells; do not use dummy cells or flexures that would hinder good performance.

Prepare the Mounting Location

To insure precise operation, the mounting surface for the tank mount top and bottom plates must be level. If the mounting surfaces are not level, use shims and/or grout to level the surface. The top and bottom plates must be level within $\pm 0.5^\circ$.

NOTE: Be sure to use dummy load cells during installation to avoid overloading the actual load cell.

Determine where to position the tank mount assembly and in which direction it should be oriented. The tank mount assembly is designed to allow for lateral movement in the direction perpendicular to the load cell.

Mechanical

- Support the load cell mounts on a rigid structure so that all points are equally supported and the vessel stays vertical. Vehicular traffic or other forces must not cause deflection of the vessel's support structure.
- Ladders, pipes and check rods, etc. must have as little interaction with the vessel as possible.
- Where piping or conduit must be attached to the vessel: Use the smallest diameter, thinnest walled pipe that will meet all other specifications. Use the longest reasonable unsupported **horizontal** length to connect the vessel. 25 times the pipe diameter as a minimum to the first support or use a **horizontally** mounted flexible connection.
- There must be no tension between electrical cables or hoses and the vessel.
- Mount pneumatic solenoids for integral gates or valves **on the vessel** then connect the supply lines horizontally as in piping.
- Attached piping is usually the largest source of error in vessel weighing. The lower the capacity of the vessel the more likely inaccuracies of this type will be apparent. Correctly installed piping and electrical connections followed by an in place calibration will result in the best system performance.

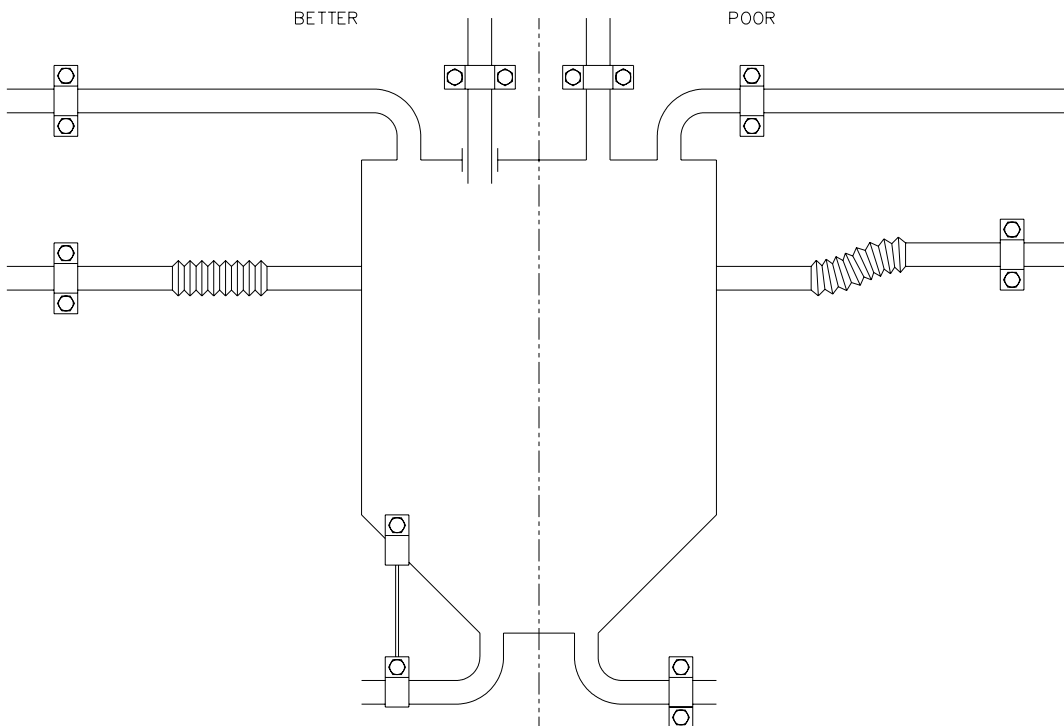

Installation

Concrete Footing or Floor

1. Position tank mount assembly bottom plate on foundation and use as a template for hole patterns.
2. Remove bottom plate drill holes.
3. Install threaded rods in the foundation. Make sure the rods line up with the holes in the tank mount assembly plates.
4. Install leveling nuts on threaded foundation rods.
5. Place tank mount assembly over threaded rods and align tank mount assembly in plane of maximum thermal expansion/contraction.
6. Loosely attach nuts to foundation rods and tank mount assembly. Do not tighten nuts at this time.
7. Level and plumb the tank mount assembly (0.5°).

Metal Structure

1. Position tank mount assembly on beam or support and use as a template for hole patterns. Be sure to center the tank mount with shear center of support beam.
2. Remove tank mount assembly and drill holes.
3. Align tank mount in plane of maximum thermal expansion/contraction.
4. Install bolts and nuts loosely. Do not tighten at this time.
5. Level and plumb the tank mount assembly (0.5°).

ITA Only

Install the ITA as you would most tank mount load cells. The following is a guide to insure maximum performance from your system.

Prepare the ITA: The ITA top Plate must move freely. **Every ITA comes from the factory correctly assembled and locktighted and should not require adjustment.**

The load must be applied vertically to the load cells.

- a. Use a level to insure that the base plate is level. If not, level the supporting points, if this is not possible then shim the load cell base plate.
- b. Use a level to insure that the load cell is level then lower the vessel close to the load cell.
- c. Visually inspect the foot of the vessel support to insure that it aligns evenly with the level load cell. If it does not, shim the foot so that the load cell remains level.

If a temperature insulator is required between the foot and the load cell, use only a rigid isolator. Only the outer load cell ring may contact the foot or insulator.

If the ITA has been disassembled for any reason, perform the following:

- a. Remove the large center screw.
- b. Align the convex load disc and the load cell with the center hole in the base plate.
- c. Locktight and install the large screw and continue to turn it until the Rubber O-Ring just contacts the convex load disc.
- d. Back the screw off ¼ turn. The Screw provides lateral restraint and lift off protection, never remove it or back it off more than the suggested amount.



The center portion of the ITA load cell mount is not live. Therefore, if any part of the tank leg or adapter plate makes contact with the center, it will affect the weighing accuracy of the system.

CALIBRATION

- Ideally the vessel will have a means of hanging weight from the corners of the vessel to trim the load cell outputs and for calibration. If it is not possible use test weights to calibrate, a known amount of product or substitute should be used.
- Calibration in place can help compensate for interference from piping, electrical connections and slightly misaligned load cells.

MAXIMIZE OPERATIONAL ACCURACY

- If using a GSE indicator, try the Future Gross parameter. This feature calculates the cutoff point based on current flow rate and a manually entered freefall time.
- An evenly flowing material can be most accurately measured. Reduce to a minimum the surging (i.e. diaphragm pump) of liquids while a weight reading is being taken.
- Slow down the filling cycle as much as possible or use a 2-speed fill cycle to reduce to a minimum the amount of freefall material when nearing the cutoff.
- If possible, switch off any vibrating or mixing equipment while the weight is being determined.

ADDITIONAL CONSIDERATION



The GSE tank mounts are self checking with integral lift off restraint, however, additional vessel restraints may be required to prevent a vessel from falling from unexpected forces, protect connections from fatigue or to keep connections aligned.

Check Rods and Stay Rods can be identical with the exception of the actual connection to the vessel. The following Table lists their traits and uses.

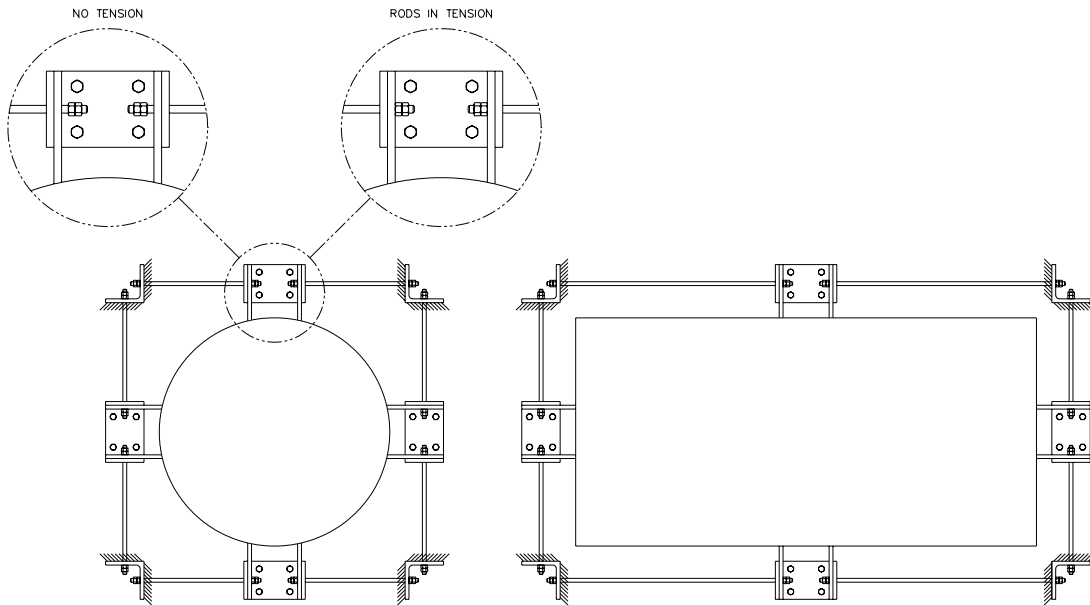
Check Rods	Stay Rods
Prevent excessive Motion	Prevent any Horizontal Motion
Can be mounted Vertically for suspended vessels. Used to prevent falling in case of a catastrophic load cell failure.	Cannot be used vertically
Mounting is Tangential for Circular Vessels – Parallel for Rectangular Vessels	
Installed without Tension or Compression	Installed with slight Tension
Should have no effect on accuracy	Should have minimal effect on accuracy. Length and diameter of the rod directly influences this. Use the longest, thinnest rod of suitable strength.

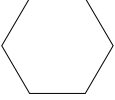
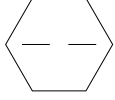
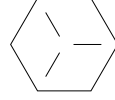
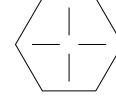
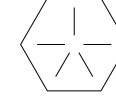

Never Exceed Recommended Bolt torque. An over torqued bolt can be structurally weakened.

LC ...Low Carbon MC...Medium Carbon Q...Quenched T...Tempered Steel A...Alloy	 SAE 0-2 LC 74000 PSI	 SAE 3 MC 100000 PSI	 SAE 5 MC T 120000 PSI	 SAE 6 MC QT 133000 PSI	 SAE 7 MC QTA 133000 PSI	 SAE 8 MC QTA 150000 PSI
Bolt-Coarse *Fine	Approximate Dry Torque Coarse / Fine					
1/4-20 *28	4/6	9/10	10/11	10/12	10/12	12/14
5/16-18 *24	9/12	17/19	19/21	21/23	21/24	25/29
3/8-16 *24	16/22	30/33	33/36	39/44	40/45	45/50
7/16-14 *20	24/34	47/51	54/59	60/69	60/70	70/80
1/2-13 *20	38/52	69/75	78/85	94/99	95/100	110/120
9/16-12 *18	52/71	103/112	114/124	133/147	135/150	150/170
5/8-11 *18	98/115	145/158	154/168	135/205	140/210	220/240
3/4-10 *16	155/180	234/255	257/280	310/350	320/360	380/420
7/8-9 *14	206/230	372/405	382/416	500/560	520/580	600/660
1-8 *14	310/350	551/600	587/640	780/840	800/860	900/990
1 1/8-7 *12	480/523	794/865	872/950	1305/1425	1325/1444	1430/1559
1 1/4-7 *12	675/736	1105/1204	1211/1320	1790/1950	1825/1989	1975/2153
1 3/8-6 *12	900/981	1500/1635	1624/1770	2425/2655	2500/2725	2650/2888
1 1/2-6 *12	1100/1200	1775/1935	1943/2118	2915/3175	3000/3270	3200/3488
Lubrication Factors	Zinc Plate	Cadmium Pl	Chrome Pl	Dry Film	Oil	Oil/Graphite
	-15%	-25%	N/C	-50%	-15-40%	-55%

ITA DIMENSIONAL DRAWINGS

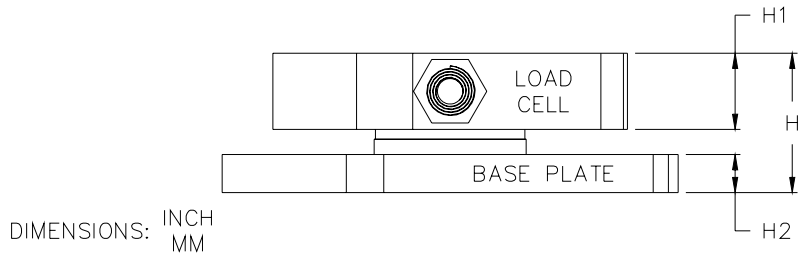
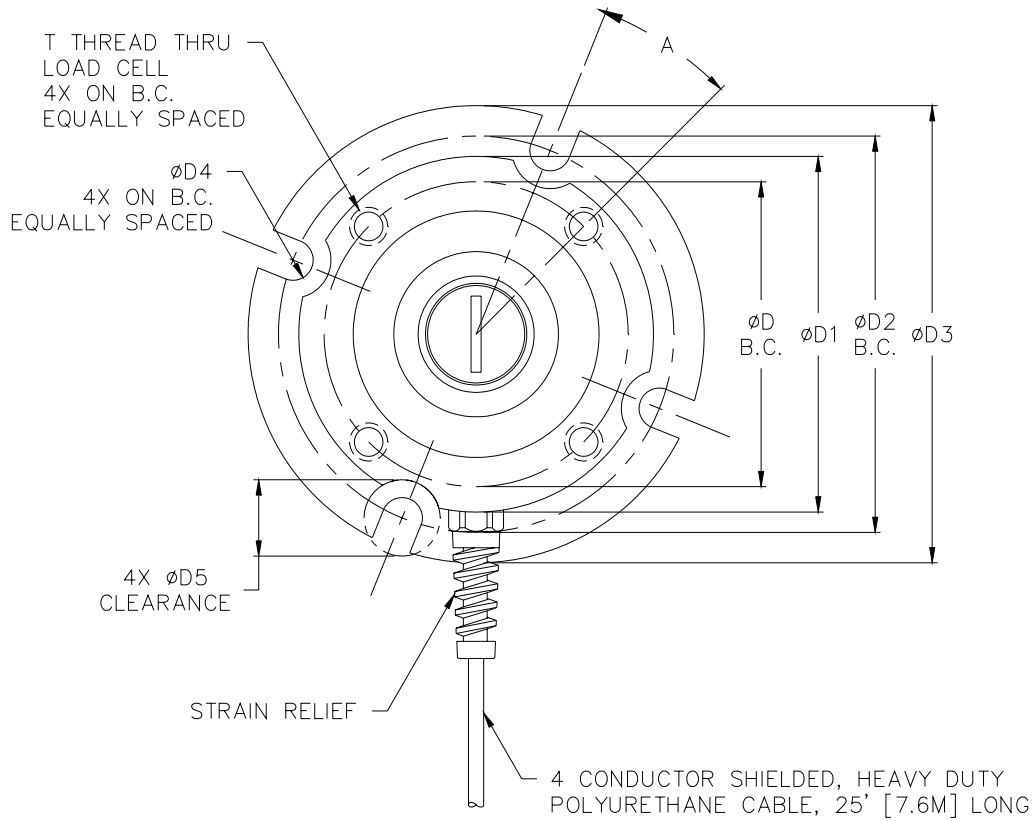

RATED CAPACITY (LBS)	H	H1	H2	D	D1	D2	D3	D4	D5	A	T
1K - 10K	1.37 34.9	0.75 19.1	0.375 9.5	3.000 76.2	3.50 88.9	3.900 99.1	4.50 114.3	0.400 10.2	0.75 19.1	23.0°	3/8-16
20K - 50K	2.53 64.3	1.30 33.0	0.75 19.1	4.825 122.6	5.50 139.7	6.250 158.8	7.00 177.8	0.563 14.3	1.25 31.8	17.0°	1/2-13
60K - 125K	3.12 79.2	1.50 38.1	1.00 25.4	5.500 139.7	6.50 165.1	7.000 177.8	8.00 203.2	0.813 20.7	1.75 44.5	52.5°	3/4-16

Figure 1: ITA Dimensions 1 K to 125 K

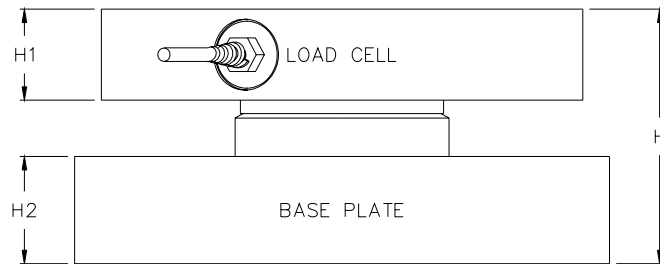
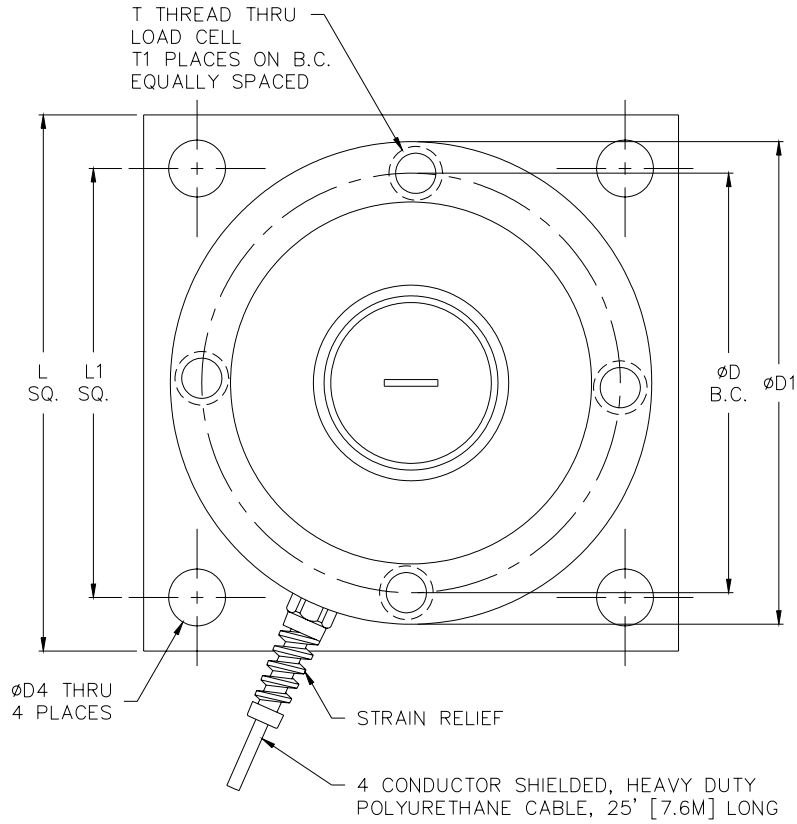

DIMENSIONS: INCH
MM

RATED CAPACITY (LBS)	H	H1	H2	L	L1	D	D1	D4	T	T1
150K - 225K	4.75 120.7	1.70 43.2	2.00 50.8	10.00 254.0	8.00 203.2	7.825 198.8	9.00 228.6	1.06 26.9	1-12	4
250K - 450K	6.40 162.6	2.25 57.2	3.00 76.2	11.00 279.4	9.00 228.6	7.750 196.9	9.00 228.6	1.31 33.3	7/8-14	6

Figure 2: ITA Dimensions 150 K to 450 K

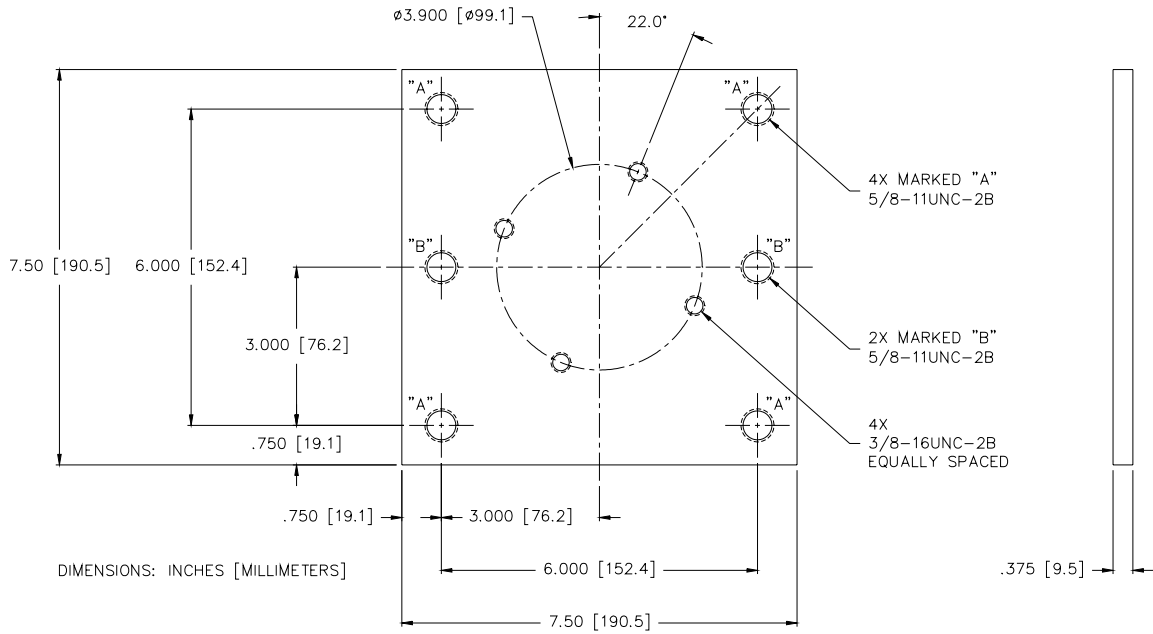

Figure 3: Mounting Plate Dimensions 1K - 10K

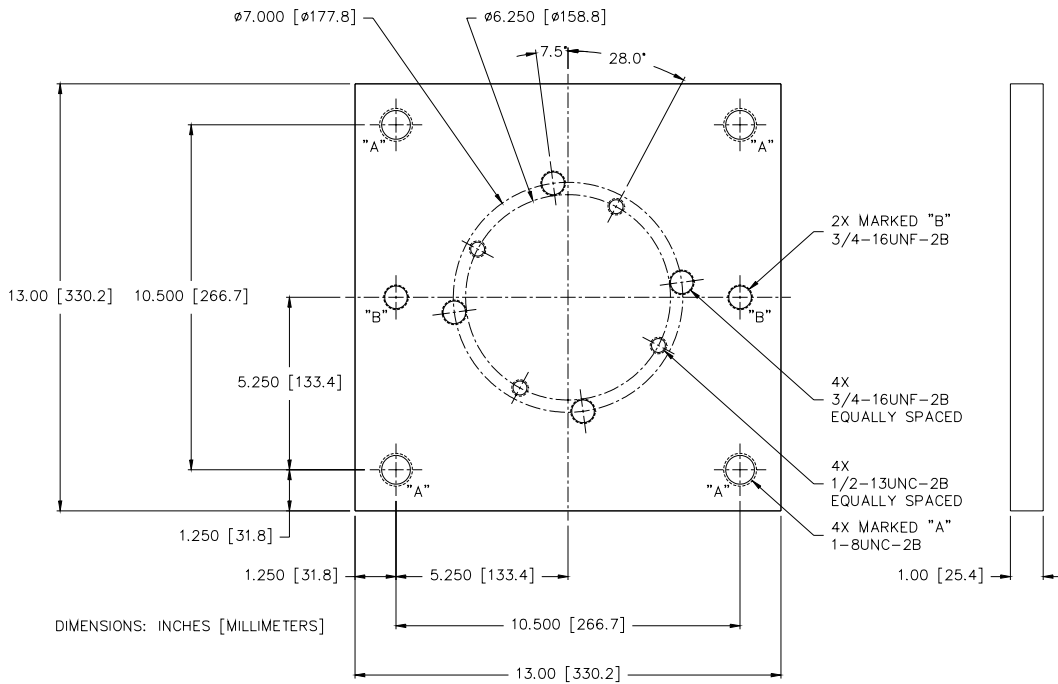

Figure 4: Mounting Plate Dimensions 20K - 125K

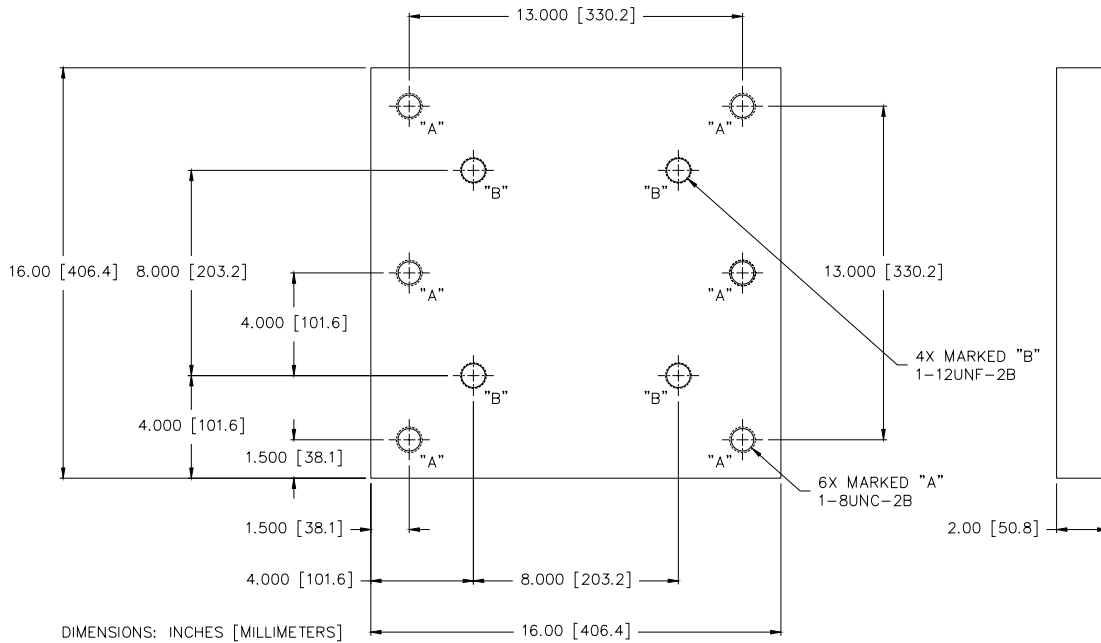

Figure 5: Mounting Plate Dimensions 150K - 225K

Load Cell Specifications

	1K to 10 K	20 K to 50 K	60 K to 125 K	150 K to 225 K
Construction	Stainless Steel, Hermetic	Stainless Steel, Hermetic	Stainless Steel, Hermetic	Stainless Steel, Hermetic
Exc. Voltage	10 – 15 VDC or VAC	10 – 15 VDC or VAC	10 – 15 VDC or VAC	10 – 15 VDC or VAC
Output	3 mV/V nominal	3 mV/V nominal	3 mV/V nominal	3 mV/V nominal
Temp Range	10° F to 100° F	10° F to 100° F	10° F to 100° F	10° F to 100° F
Bridge Resistance	350 Ohms nominal	350 Ohms nominal	350 Ohms nominal	350 Ohms nominal
Insulation Resistance	5000 Meg Ohms min	5000 Meg Ohms min	5000 Meg Ohms min	5000 Meg Ohms min
Linearity	0.05 % Full Scale	0.05 % Full Scale	0.05 % Full Scale	0.05 % Full Scale
Repeatability	0.01 % Full Scale	0.01 % Full Scale	0.01 % Full Scale	0.01 % Full Scale
Max load safe	150 % of rated capacity	150 % of rated capacity	150 % of rated capacity	150 % of rated capacity
Max Load ultimate	300 % of rated capacity	300 % of rated capacity	300 % of rated capacity	300 % of rated capacity

Mounting Specifications

	1K to 10 K	20 K to 50 K	60 K to 125 K	150 K to 225 K
Uplift Restraint	100 % of rated capacity	100 % of rated capacity	100 % of rated capacity	100 % of rated capacity
Lateral Restraint	100 % of rated capacity	100 % of rated capacity	100 % of rated capacity	100 % of rated capacity
Non- Parallel Accommodation	± 3 °	± 3 °	± 3 °	± 3 °
Thermal Accommodation	± .1 °	± .17 °	± .2 °	± .25 °

Load Cell Wiring

+ Excitation	Green
- Excitation	Black
+ Signal	White
- Signal	Red

6600/6700 DIMENSIONAL DRAWINGS

Model 6600 Single Ended Assembly

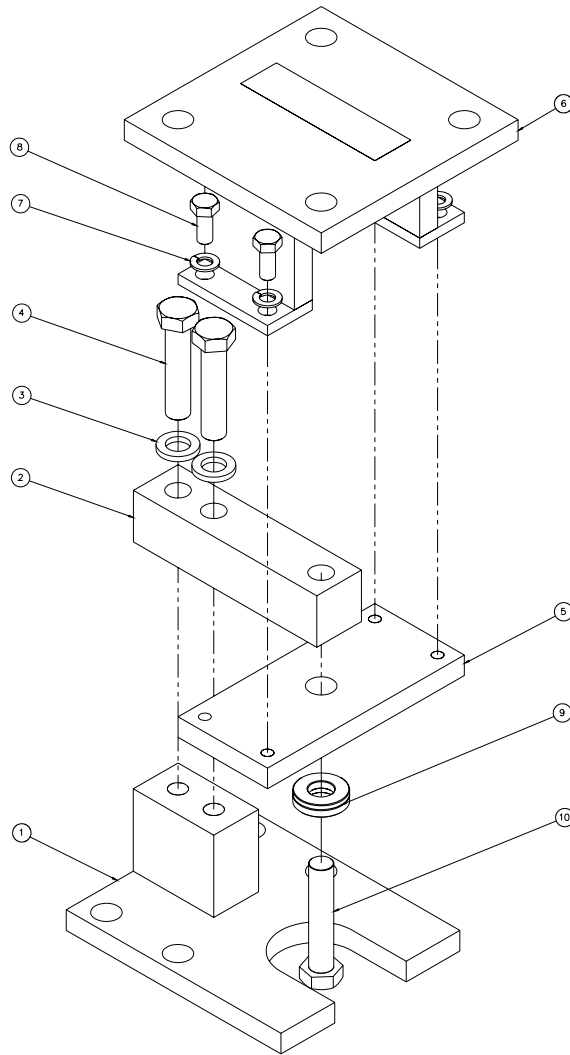

Balloon	Quantity	Carbon Steel Part Number	Stainless Steel Part Number	Description
1	1	44-45-43431	44-45-43434	Tank assembly base
2	1	34-01-XXXXX	34-08-XXXXXA	Loadcell sensor
3	2	38-56-1410		1/2" split lock washer, Stainless Steel
4	2	38-56-8970		1/2" - 13X2.25, hex HD, Stainless Steel
5	1	44-10-43433	44-10-43436	Tank attach plate,
6	1	44-45-43432	44-45-43435	Tank support
7	4	38-44-1355		5/16" washer, split lock, Stainless Steel
8	4	38-44-5815		5/16" - 18x0.75, hex HD, Stainless Steel
9	1	38-56-1500	38-56-1510	1/2" self aligning washer
10	1	38-60-8835		1/2" - 20x2.25, hex HD, Stainless Steel

Model 6700 Double Ended Assembly

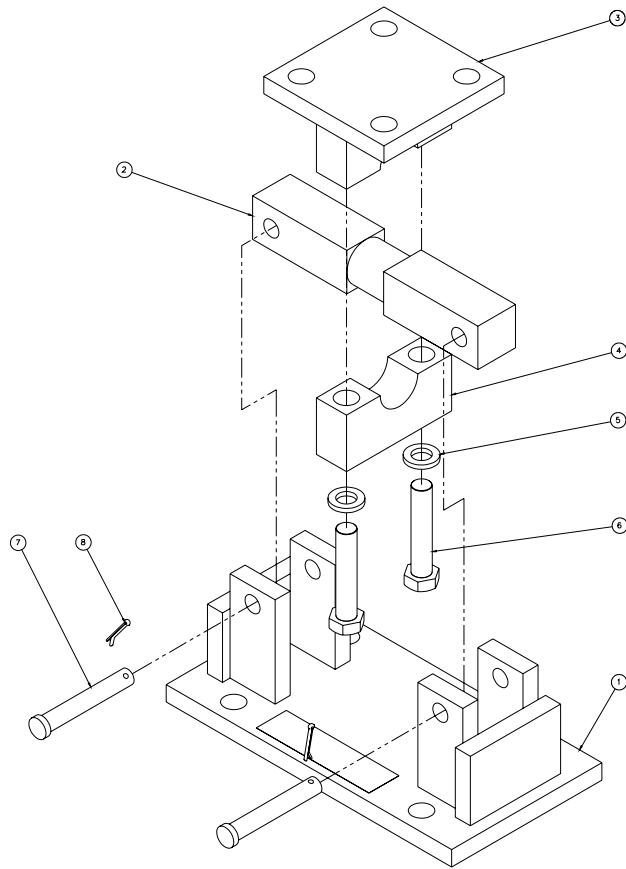

Balloon	Capacity	Quantity	CS Part Number	SS Part Number	Description
1	1 – 5K	1	44-45-43441	44-45-43445	Tank assembly base
	10 – 25K		44-45-43451	44-45-43455	
	50K		44-45-43468	44-45-43472	
	75K		44-45-43475	44-45-43478	
2		1	34-01-XXXXX		Loadcell sensor
3	1 – 5K	1	44-45-43442	44-45-43446	Tank support
	10 – 25K		44-45-43452	44-45-43456	
	50K		44-45-43469	44-45-43473	
	75K		44-45-43476	44-45-43479	
4	1 – 5K	1	44-10-43443	44-10-43447	Tank attach plate
	10 – 25K		44-10-43453	44-10-43457	
	50K		44-10-43470	44-10-43474	
	75K		44-10-43477	44-10-43480	
5	1 – 5K	2	38-56-1410		1/2" split lock washer, Stainless Steel
	10 – 25K		38-77-1360		3/4" split lock washer, Stainless Steel
	50K		38-81-1300	38-81-1301	1.25" split lock washer, Stainless Steel
	75K		38-81-1300	38-81-1301	1.25" split lock washer, Stainless Steel
6	1 – 5K	2	38-56-8980		1/2" – 13X2.5, hex HD, Stainless Steel
	10 – 25K		38-77-5830		3/4" - 10X3.50, hex HD, Stainless Steel
	50K		38-81-1200	38-81-1201	1.25", 7X5.00, hex HD, Stainless Steel
	75K		38-81-1200	38-81-1201	1.25", 7X5.00, hex HD, Stainless Steel
7	1 – 5K	2	44-10-43444	44-10-43491	7/16" tank assembly rod
	10 – 25K		44-10-43454		3/4" tank assembly rod
	50K		44-10-43471		1.25" tank assembly rod
	75K		44-10-43471		1.25" tank assembly rod
8		2	38-85-165HP		3/32", DIA, Cotter pin, Stainless Steel

Load Cell Part Numbers

Model 6600

Capacity	Carbon Steel Part Number	Stainless Steel Part Number
1K	34-01-03102	34-08-02102A
2K	34-01-03202	34-08-02202A
2.5K	34-01-03252	34-08-02252A
4K	34-01-03402	34-08-02402A
5K	34-01-04502	34-08-02502A

Model 6700

Capacity	Carbon Steel Part Number	Stainless Steel Part Number
2K	34-01-10202	34-01-11202
2.5K	34-01-10252	34-01-11252
3K	34-01-10302	34-01-11302
5K	34-01-10502	34-01-11502
10K	34-01-12103	34-01-13103
15K	34-01-12153	34-01-13153
20K	34-01-12203	34-01-13203
25K	34-01-12253	34-01-13253
50K	34-01-14503	34-01-15503
75K	34-01-14753	34-01-15753

Load Cell Specifications

	Mild Steel Single Ended	Stainless Steel Single Ended	Mild Steel Double Ended	Stainless Steel Double Ended
Construction	Alloy tool steel	Stainless steel	Alloy tool steel	Stainless steel
Cable Length	20 feet (6.1 m)		25 feet (7.62 m)	25 feet (7.62 m)
Exc. Voltage	15 VDC	15 VAC/VDC	15 VAC/VDC	15 VAC/VDC
Output	3 mV/V	3 mV/V	3 mV/V	3 mV/V
Temp Range	0 °F to 150 °F (-18 °C to 65 °C)	-4 °F to 140 °F (-20 °C to 60 °C)	0 °F to 150 °F (-18 °C to 65 °C)	0 °F to 150 °F (-18 °C to 65 °C)
Bridge Resistance	350 ohm	350 ohm	700 ohm	700 ohm
Non - Repeatability	± 0.01 % of rated output	± 0.02 % of rated output	± 0.01 % full scale output	± 0.01 % full scale output
Safe Overload	150 % of Rated capacity	150 % of Rated capacity	150 % of Rated capacity	150 % of Rated capacity
Ultimate Overload	300 % of Rated capacity	300 % of Rated capacity	300 % of Rated capacity	300 % of Rated capacity

Load Cell Wiring

+ Excitation	Red
- Excitation	Black
+ Signal	Green
- Signal	White

MODEL 7300 LEVERMOUNT® QUICK REFERENCE

Unpacking and Setup

1. Unpack the LeverMount® assembly and the load cell. Do not loosen the transit bolts yet. Check the items are not damaged and that all the intended parts are included. Each LeverMount® shipping assembly should contain

- 1x LeverMount® Assembly
- 1x Load Cell
- 1x Load Button

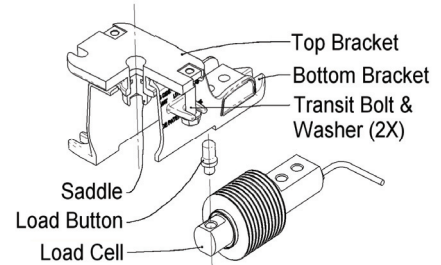

2. Rotate the saddle in the top bracket so that when the LeverMount® assembly is in its final position, the slot in the saddle will be aligned in the direction of the maximum expansion of movement, which is generally pointing into the center of the weigh vessel.

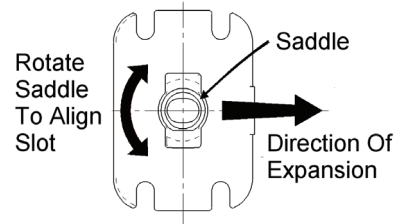

3. Mount the Levermount® assembly in position on the load bearing structure, and securely bolt it via the three slots in the bottom bracket. The attachment bolts are not supplied with the assembly and the required quantities are listed in the table below:

LeverMount® Product Type		Bolt Size	Bottom Bracket Nuts and Bolts	Top Bracket Nuts and Bolts
20 – 500 lb	LeverMount® Lite	5/16"	3	4
10 – 200 kg		M8		
1K – 5K lb	LeverMount®	7/16"	3	4
500 – 2K kg		M12		
5K – 10K lb	LeverMount®	3/4"	3	4
2K – 5K kg		M20		

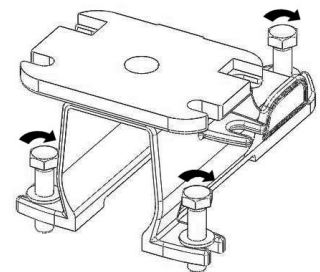

4. Position the vessel or structure to be weighed on the top bracket of the LeverMount®. Bolt the mating foot of the vessel or structure to the top bracket of the LeverMount® using two additional bolts (not supplied) in the free slots.

WARNING: The raised strip on the top bracket must be aligned with the two arrows on the mount to prevent serious injury or death.

NOTE: Be sure to consider all circumstances such as expected wind load and tank height. Additional measures may need to be taken to insure stability and prevent toppling of the weigh vessel.

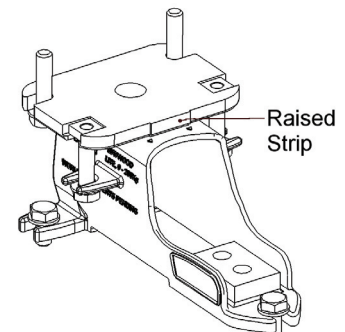

5. Loosen the two transit bolts and slide them free with the nuts. DO NOT DISCARD THE BOLTS AND WASHERS. The top bracket should be further secured to the vessel or structure using two additional bolts and washers (not supplied). Check that the top bracket raised strip is still aligned with the two arrows on the mount. At this stage the vessel is completely supported by the LeverMount® assembly.

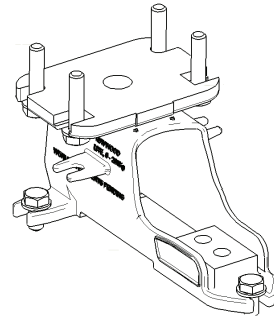

6. Ensure that the direction arrow on the front face of the load cell is pointing down and that all mating surfaces are free of debris. Fit the load button to the load cell and then slide the load cell, with the load button in place, into position within the LeverMount® assembly. Insert the two transit bolts and washers through the load cell fixing holes and hand tighten. Ensure the load cell is parallel to the center line of the LeverMount® assembly and alternately tighten the bolts.

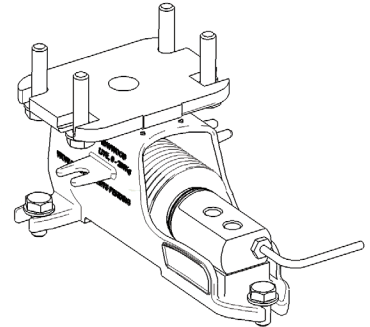

7. Alternate the tightening of the two bolts to the specified torque in the table below. This will raise the weight vessel and transfers the load to the load cell leaving it ready for operational weighing.

LeverMount® Product Type		Bolt Torque
20 – 500 lb LeverMount® Lite		24 lb-ft
10 – 200 kg LeverMount® Lite		32Nm
1k – 5k lb LeverMount®		118 lb-ft
500 – 2k kg LeverMount®		160Nm
5K – 10K lb LeverMount®		118 lb-ft to Lift 50% of capacity
2K – 5K kg LeverMount®		160Nm to Lift 50% of capacity

NOTE: Periodically check the security of the mount and the attachment vessel.

Load Cell Part Numbers

Capacity	Product	Part Number
20	LeverMount® Lite	34-02-10200
50	LeverMount® Lite	34-02-10500
100	LeverMount® Lite	34-02-10101
200	LeverMount® Lite	34-02-10201
250	LeverMount® Lite	34-02-10251
500	LeverMount® Lite	34-02-10501
500	LeverMount® Medium	34-08-02501A
1000	LeverMount® Medium	34-08-02102A
2000	LeverMount® Medium	34-08-02202A
4000	LeverMount® Medium	34-08-02402A
5000	LeverMount® Large	34-08-02502LA
10000	LeverMount® Large	34-08-02103A

Load Cell Specifications

	LeverMount® Lite	LeverMount®
Construction		316 cast stainless steel
Cable Length	9.8 feet (3 m)	16.5 feet (5 m)
Exc. Voltage	10 - 15 VAC/VDC	10 - 15 VAC/VDC
Output	2 mV/V	3 mV/V
Temp Range	-22 °F to 176 °F (-30 °C to 80 °C)	-4 °F to 140 °F (-20 °C to 60 °C)
Bridge Resistance	350 ohm	350 ohm
Non-Linearity		± 0.025% of rated output
Non-Repeatability		± 0.02% of rated output
Safe Overload	150 % of Rated capacity	150 % of Full Scale
Ultimate Overload	300 % of Rated capacity	300 % of Full Scale

Load Cell Wiring

+ Excitation	Green
- Excitation	Black
+ Signal	White
- Signal	Red

Avery Weigh-Tronix



Avery Weigh-Tronix USA

1000 Armstrong Dr.

Fairmont MN 56031 USA

Tel:507-238-4461

Fax:507-238-4195

Email: usinfo@awtxglobal.com

www.wtxweb.com

Avery Weigh-Tronix UK

Foundry Lane,

Smethwick, West Midlands,

England B66 2LP

Tel:+44 (0) 8453 66 77 88

Fax: +44 (0)121 224 8183

Email: info@awtxglobal.com

www.averyweigh-tronix.com